

10 x 10 cm

4 x 4 Inch

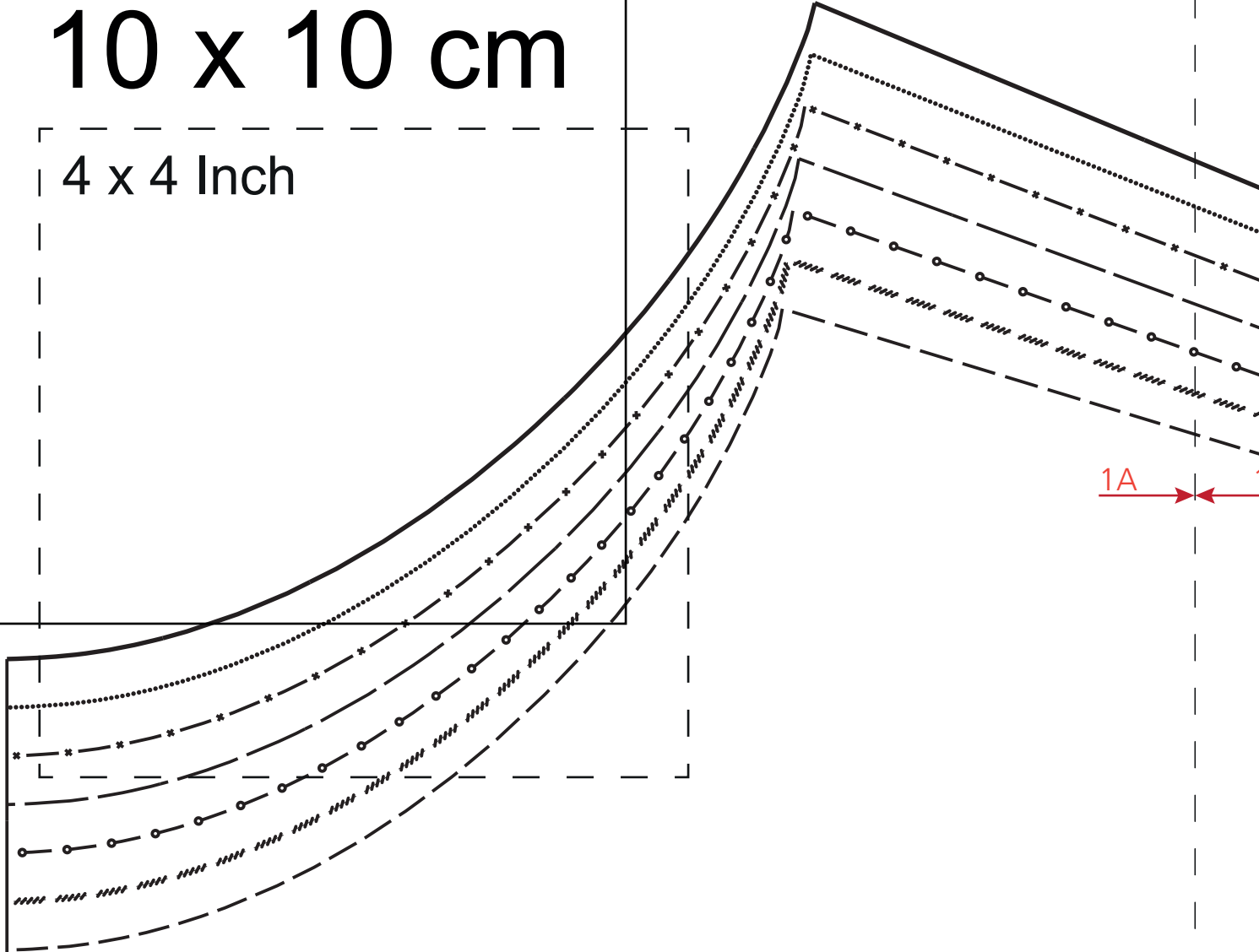

Shirt „Maja“ 7012

Vordere Mitte Stoffbruch Fadenlauf/ Centre front

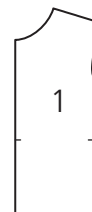

2A



A

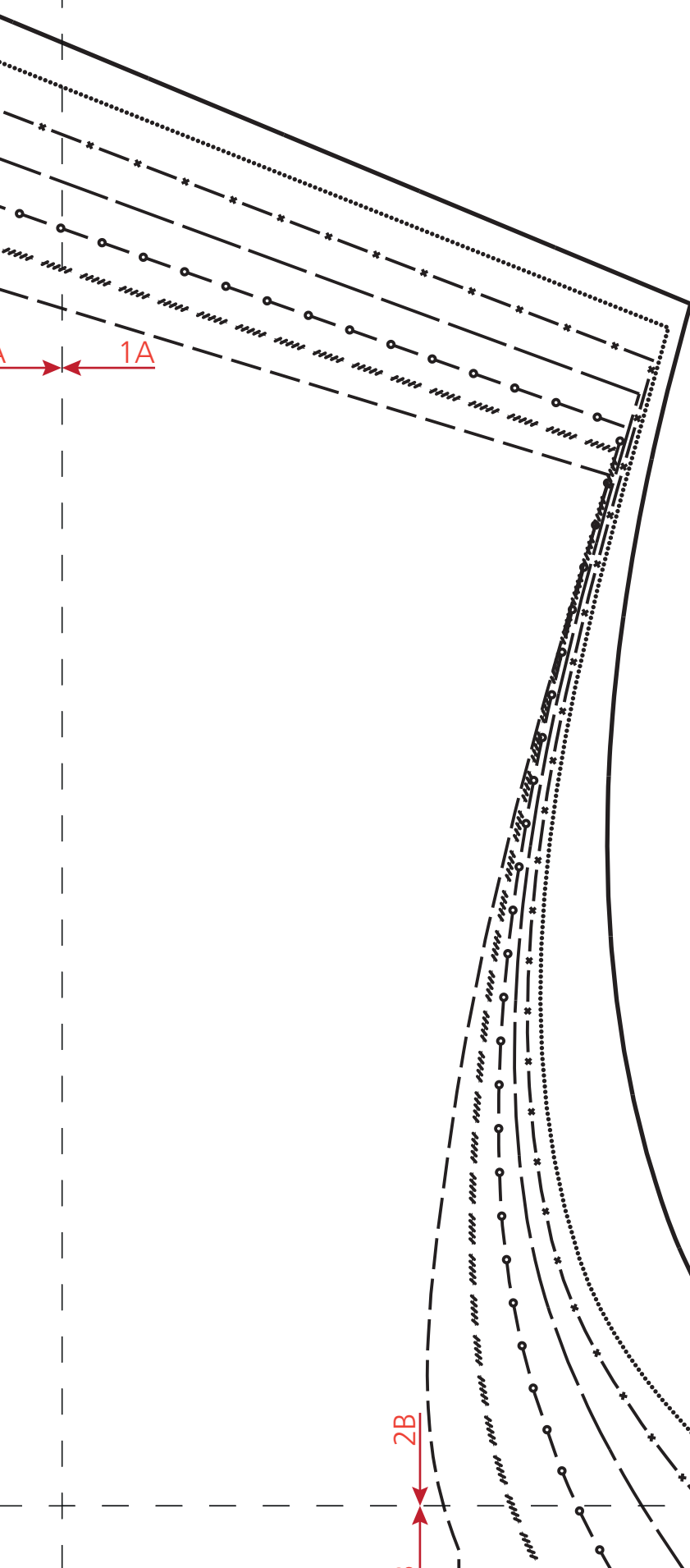

1B



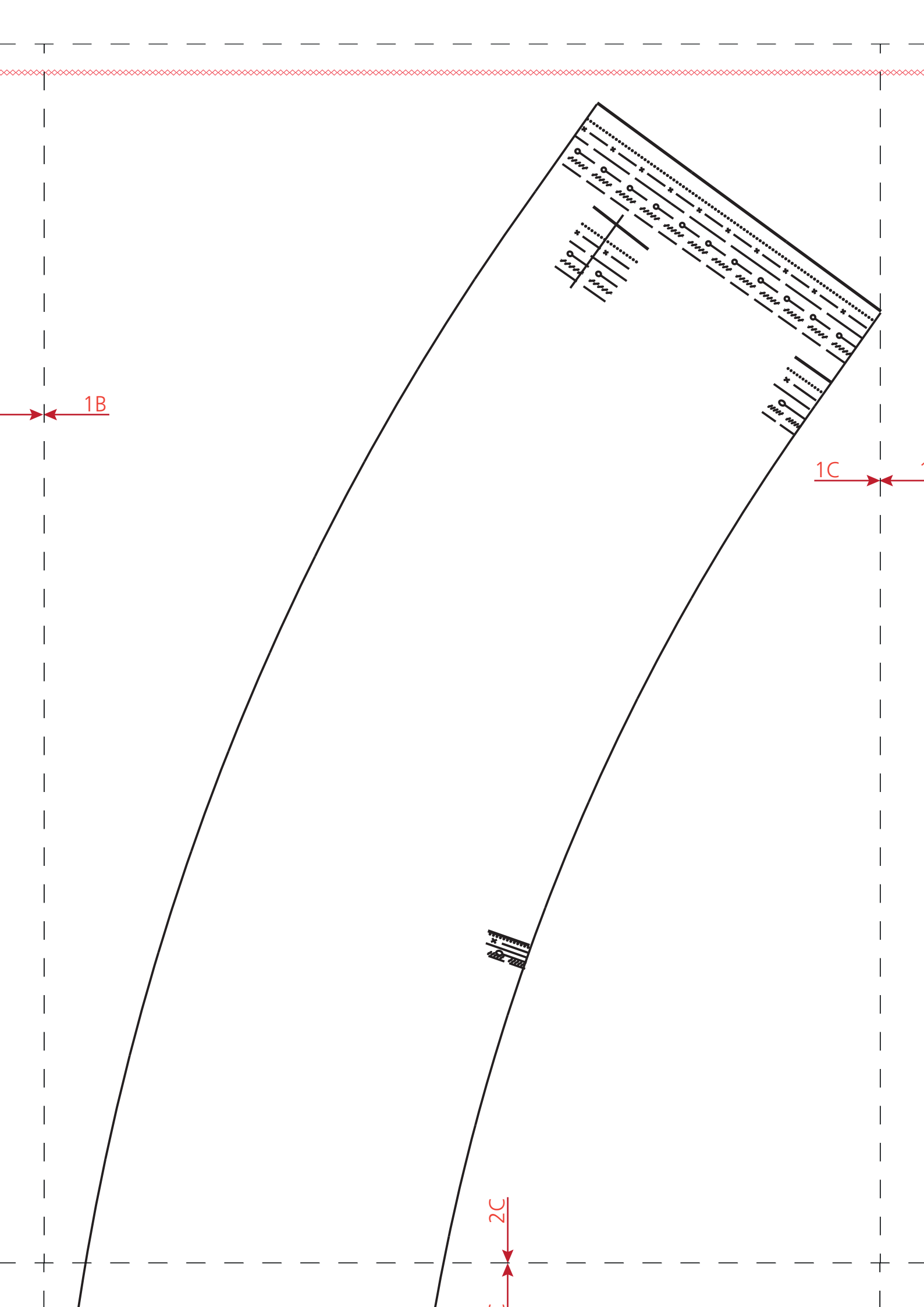

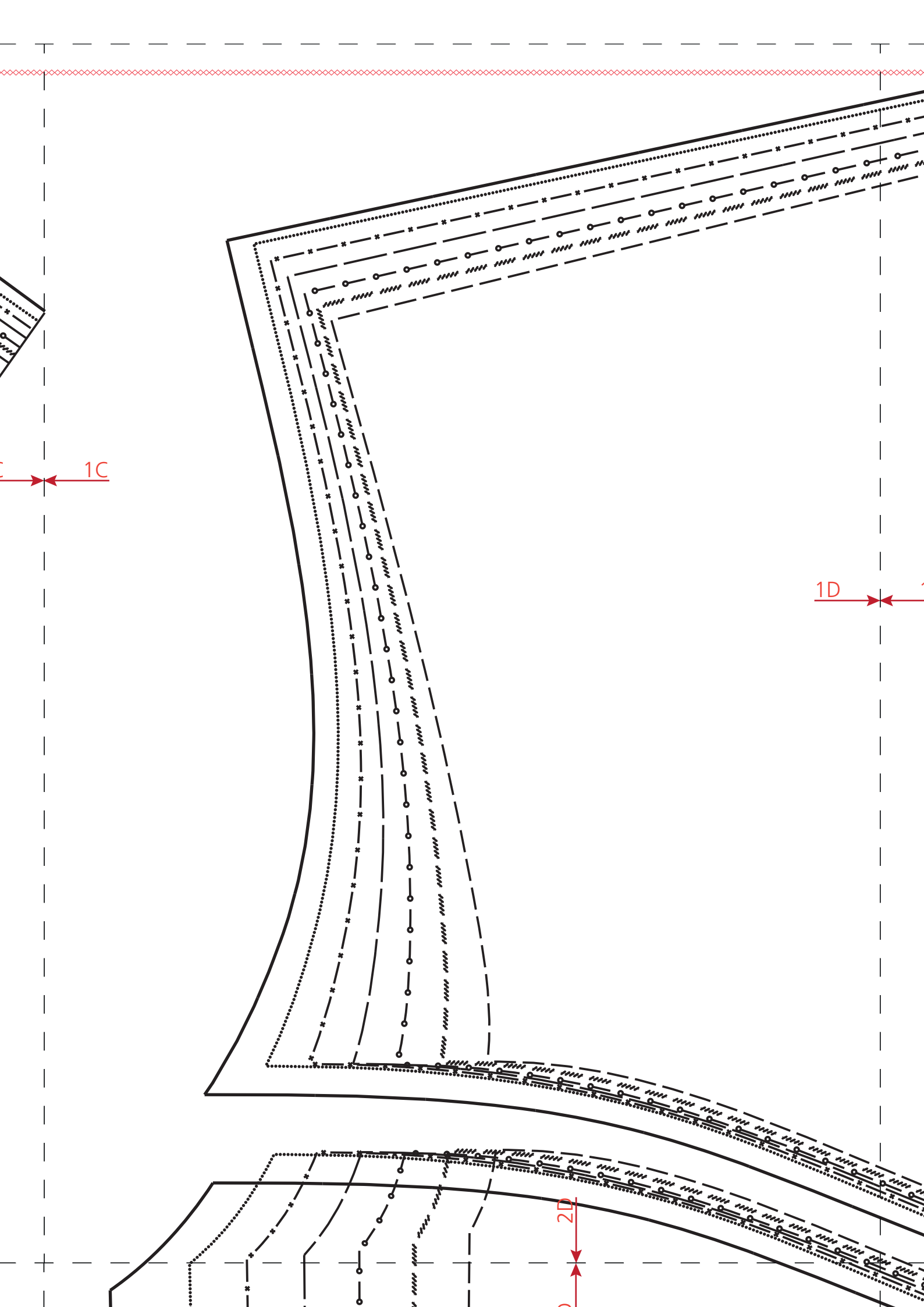

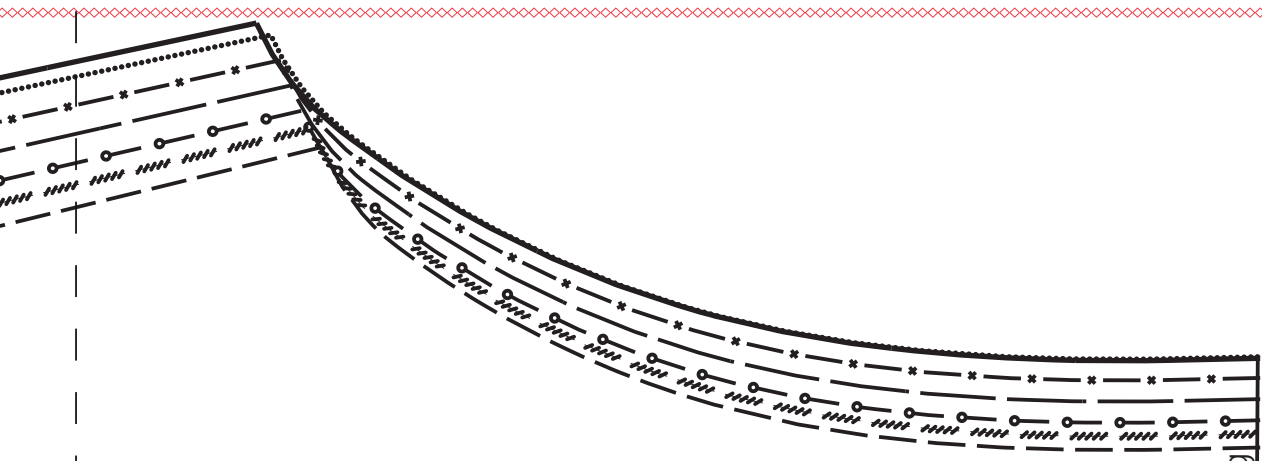

0 1D

2

Rückwärtige Mitte Fadenlauf / Centre back straight grain / Milieu envers droit - fil / Middenachter draadrichting

1E

2E

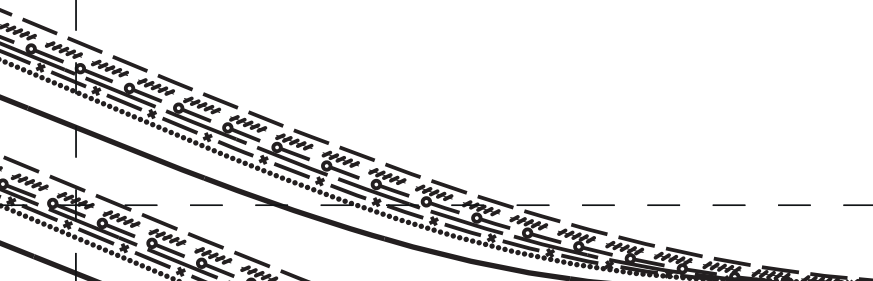

1E

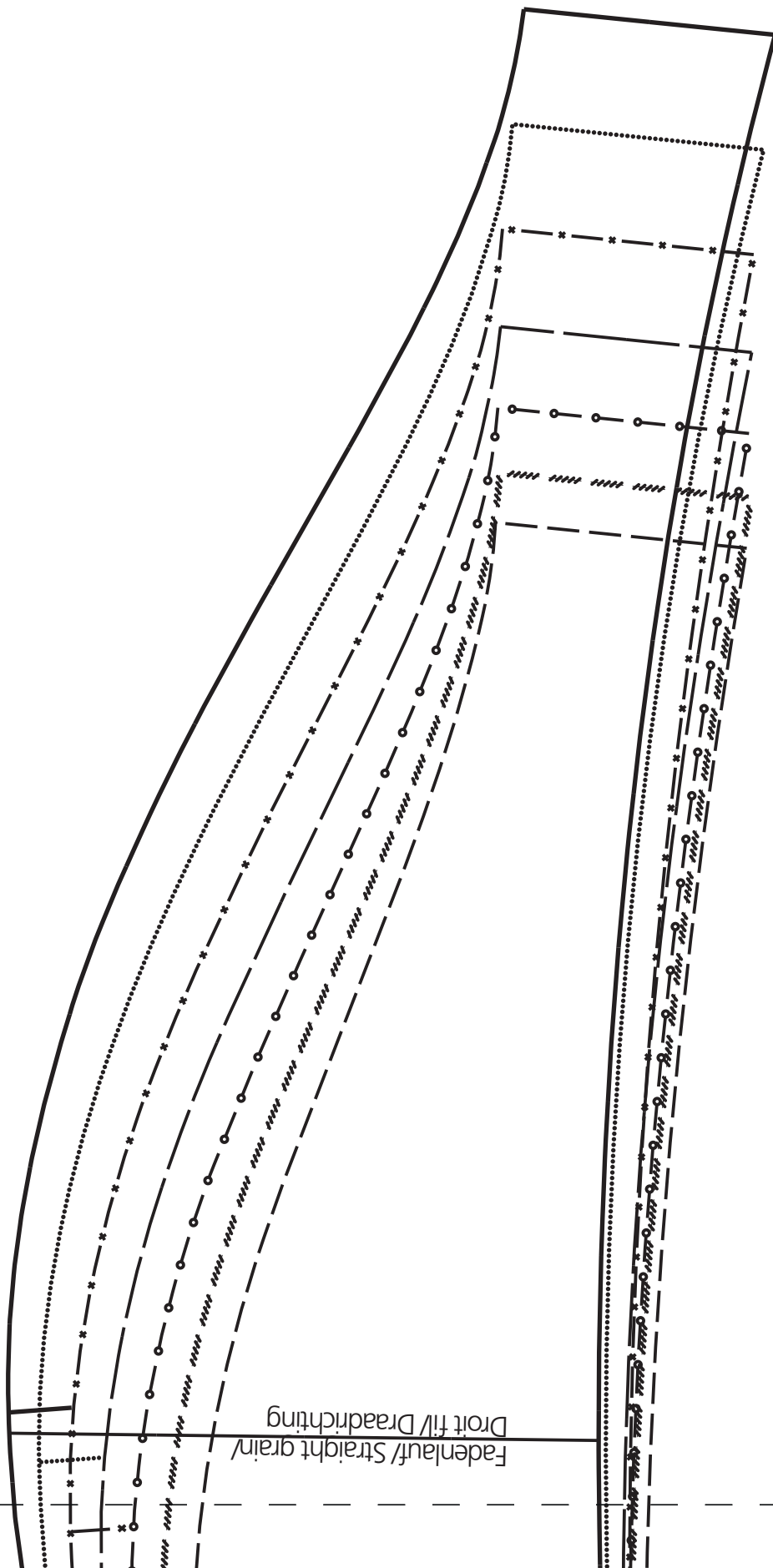

Fadenlauf/ Straight grain
Droit fil/ Draadrichting

2F

/ Centre front fold straight grain/ Milieu endroit pli droit fil/ Middenvoor stofvouw draadrichting

2A

1

2A

3A

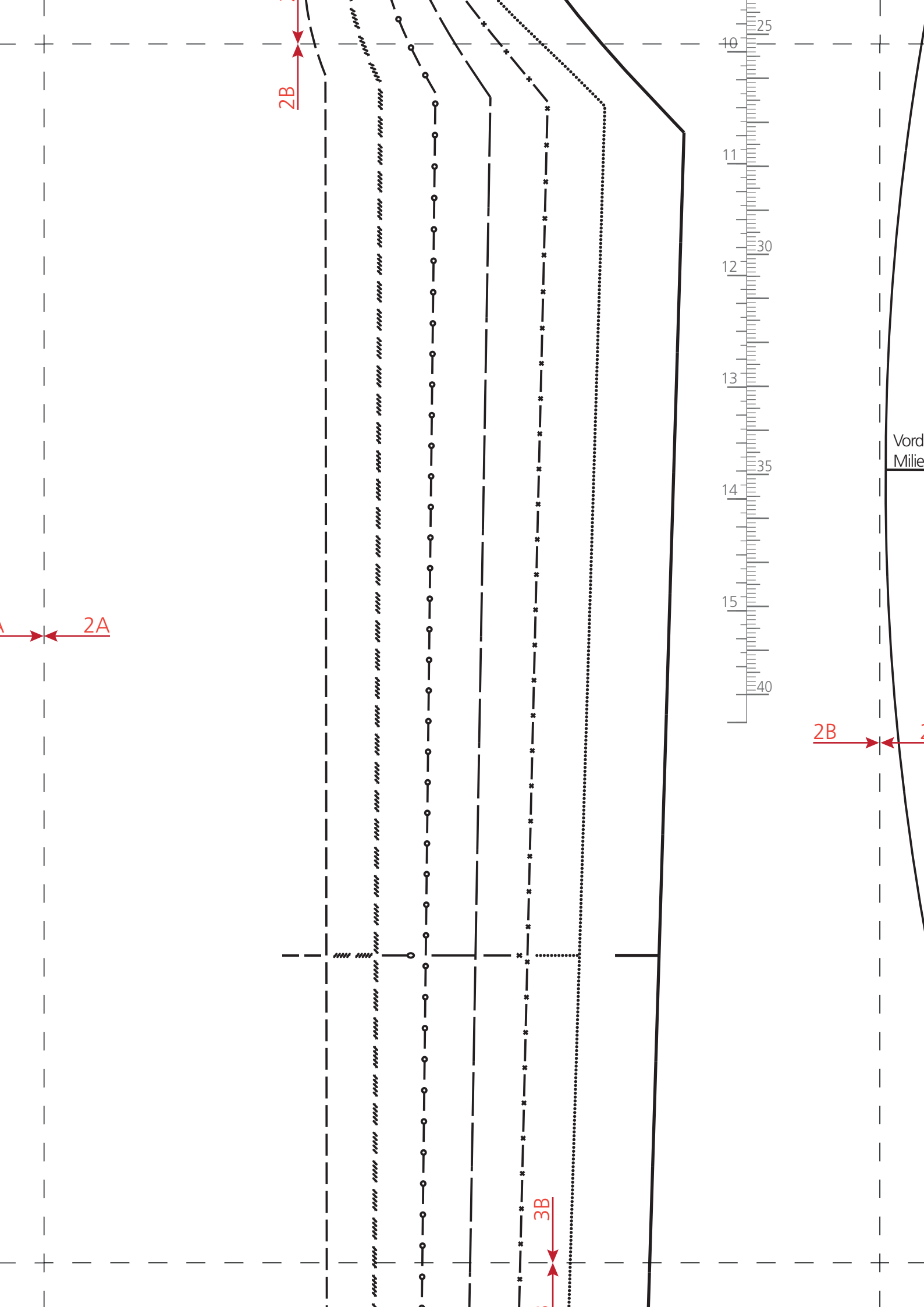

2C

Vord. Mitte Fadenlauf/ Centre front str. grain/
Milieu endroit droit fil/ Middenvoor draadrichting

4

2B

2C

3C



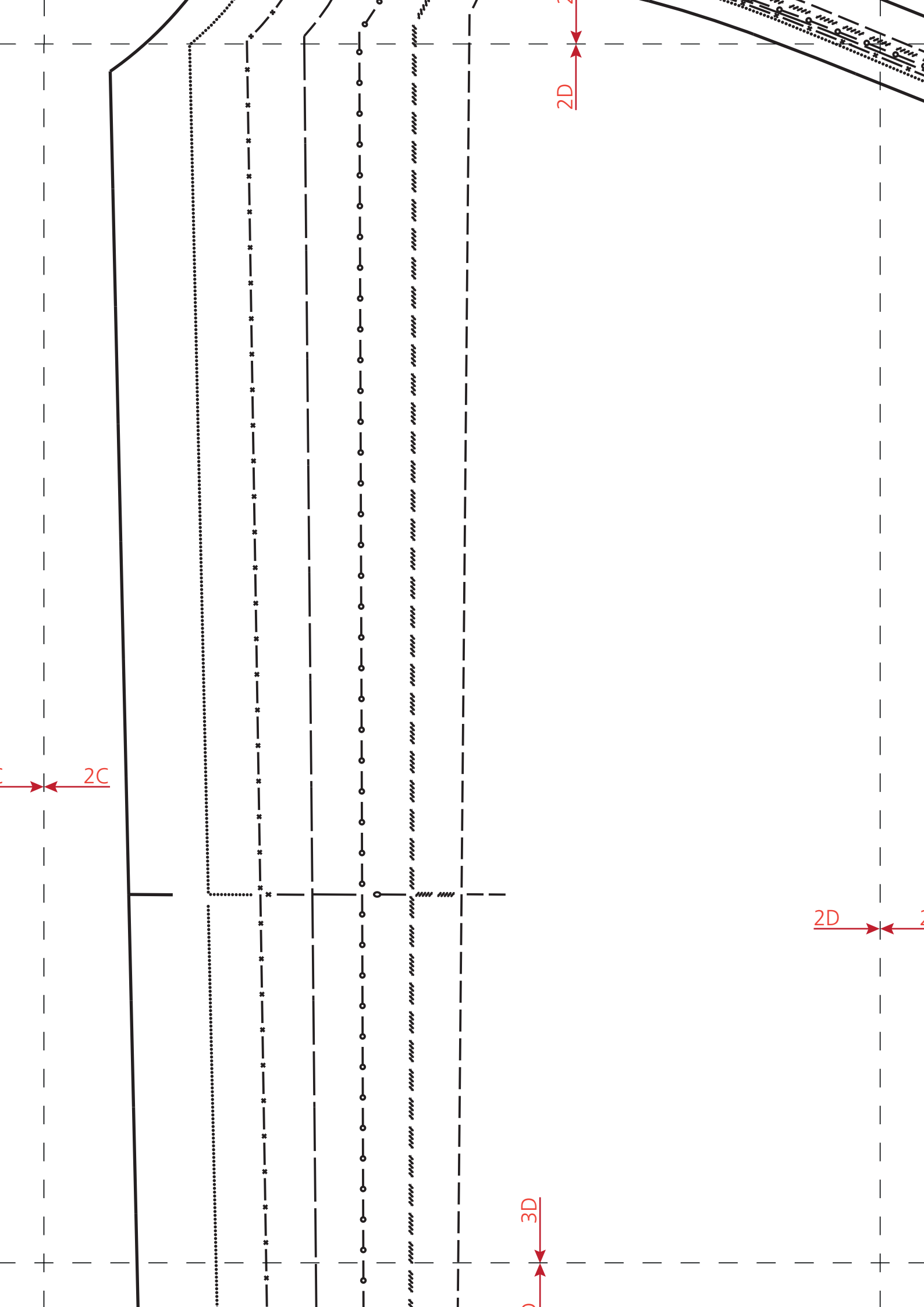

3

2D

3E

Rückwärtige Mitte Stoffbruch Fadenlauf / Centre back fold straight grain / Milieu envers pli droit fil / Middenachter stofvouw Draadrichting

2E

2E

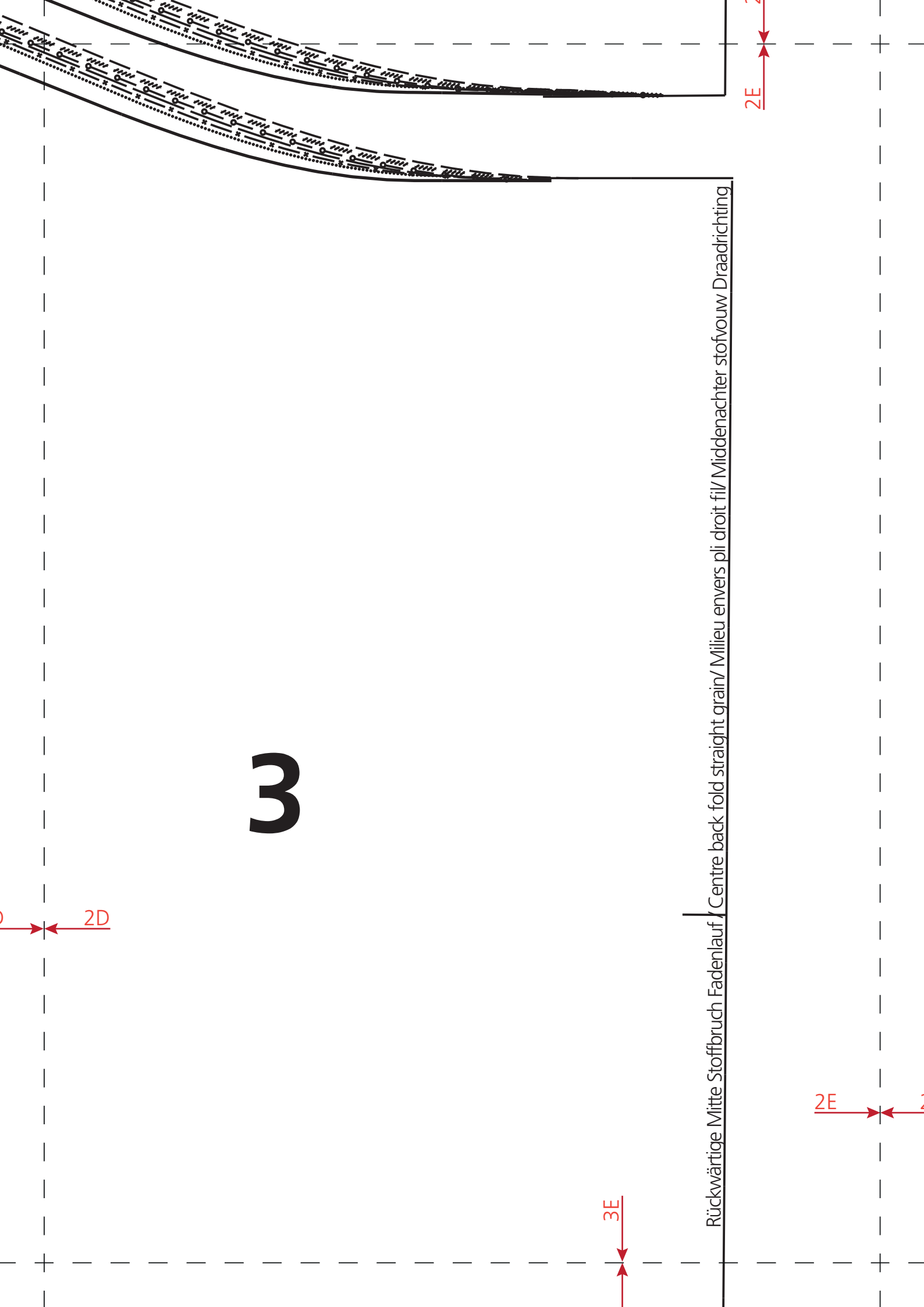

2F

5

Fadenlauf/ Straiçht grain

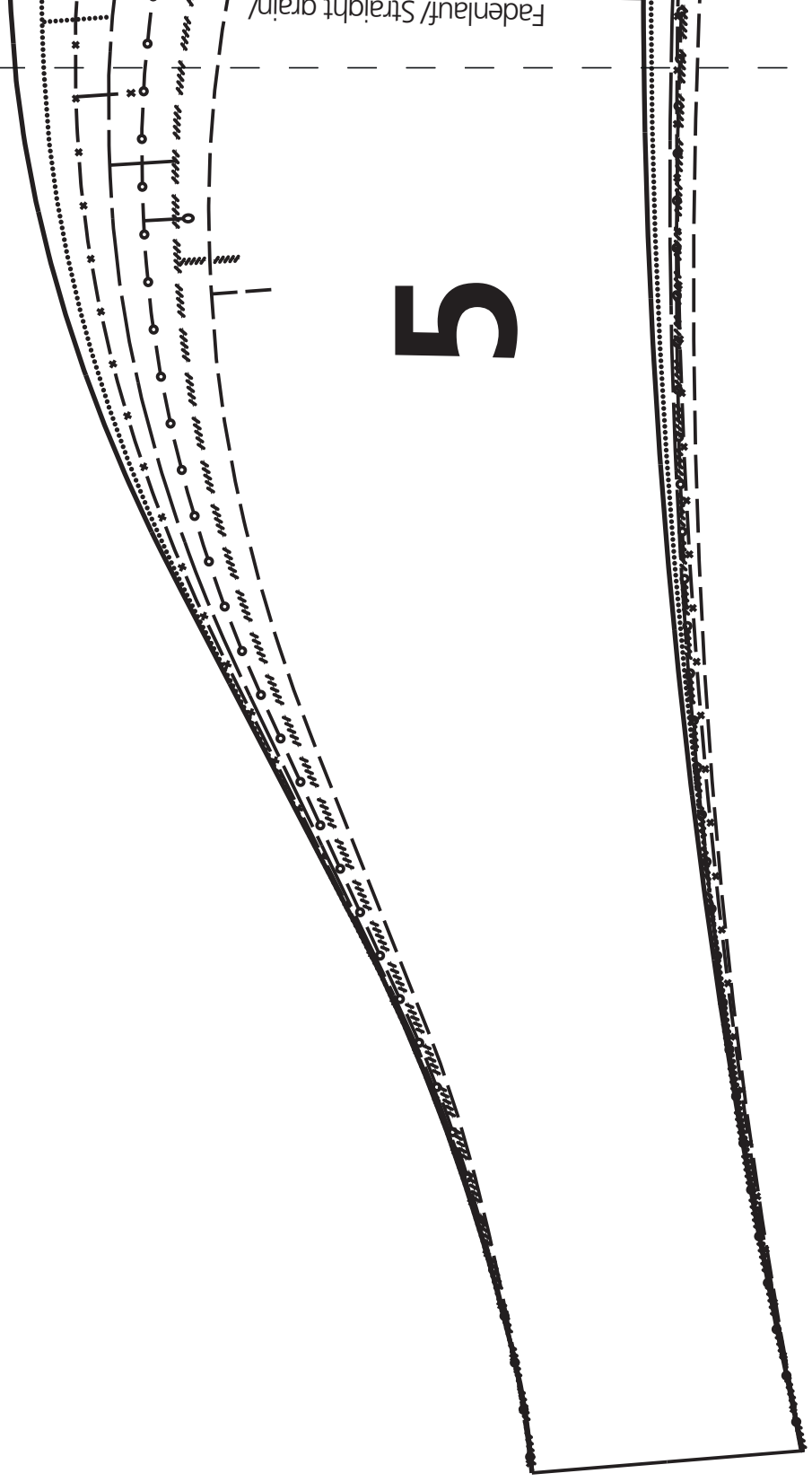

3F

2E

$3A$

$3A$

3A

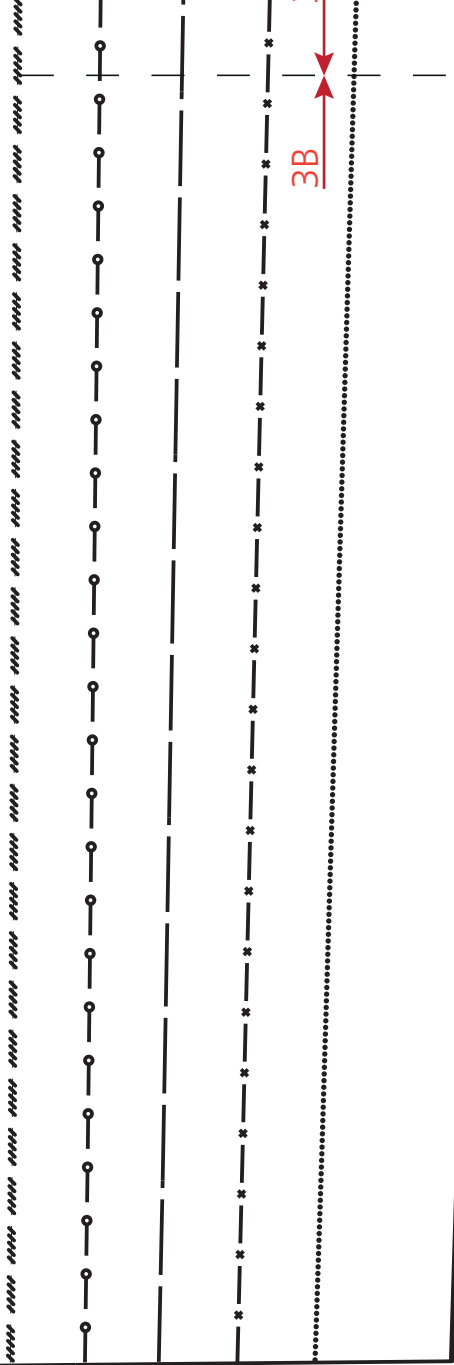

3B

3B

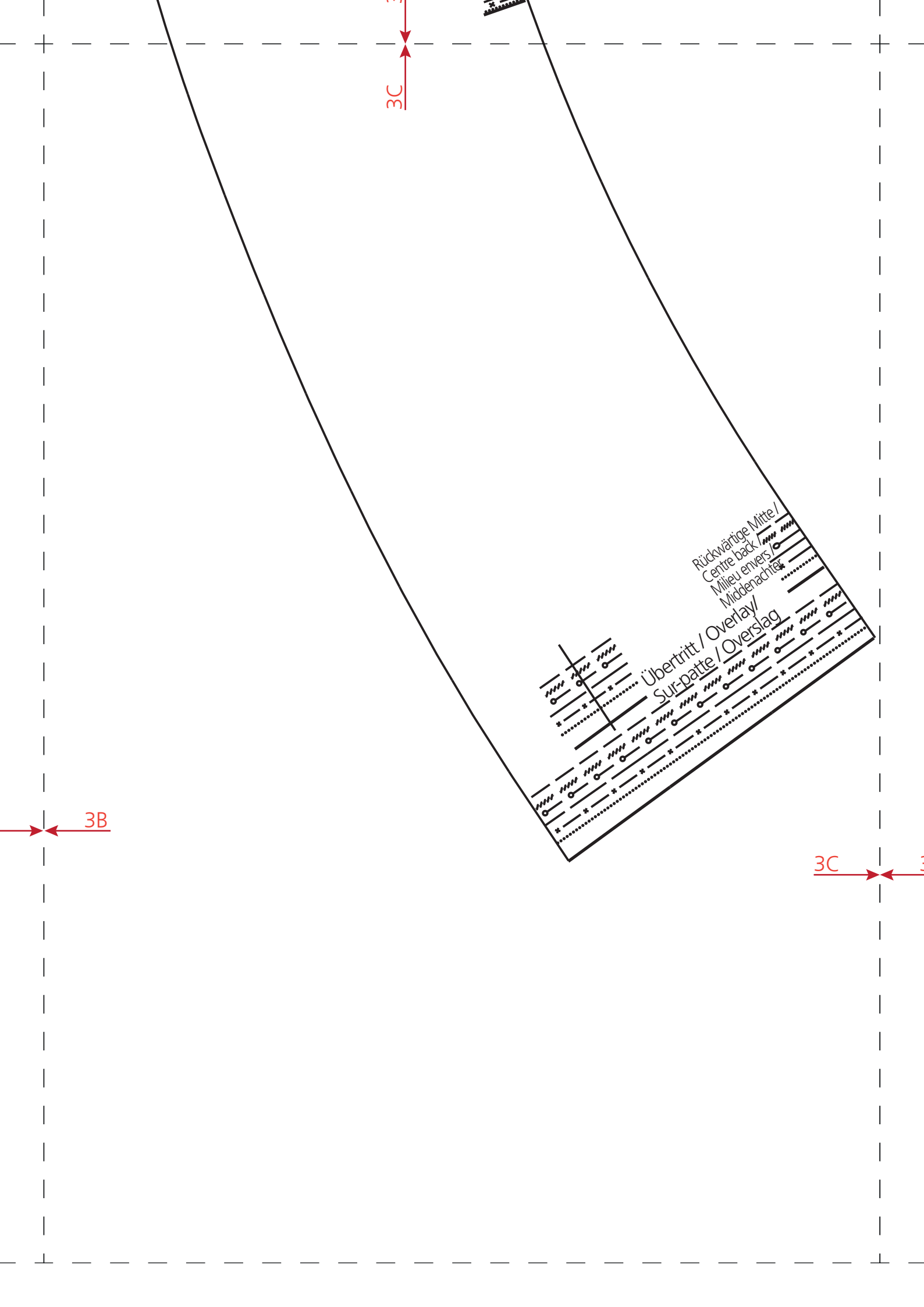

3C

3B

3C

Rückwärtige Mitte /
Centre back /
Milieu envers /
Middenachter

Übertritt / Overlay /
Sur-patte / Overslag

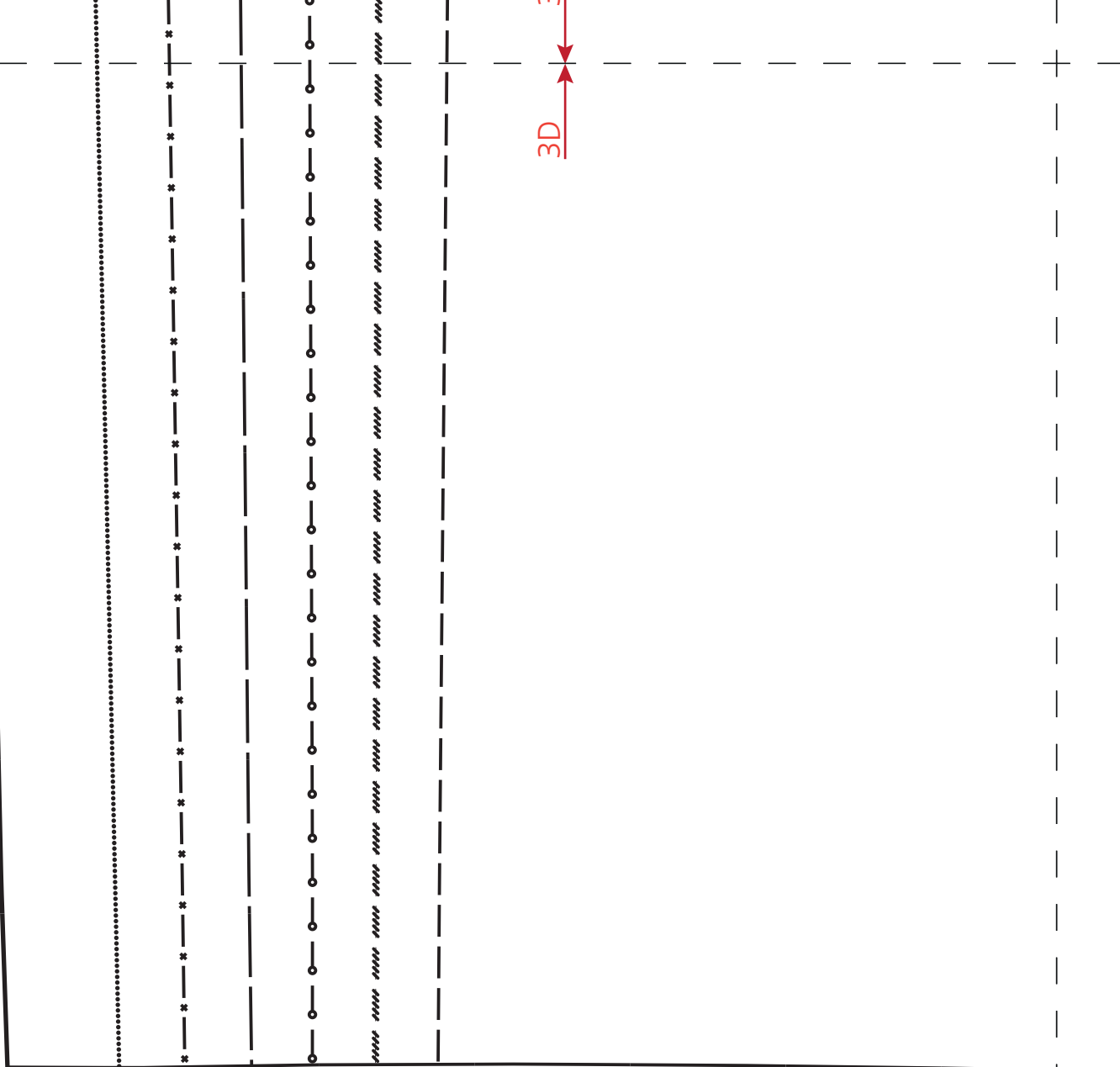

Für Körpergröße/ for height/ pour la taille/ Maten voor lichaamsgrootte 168 cm

Größe/ Size/ Taille/ Maat	34	36	38	40	42	44	46	48
Oberweite/Bust/ Poitrine/ Bovenwijdte	80	84	88	92	96	100	104	110
Taillenweite/ Waist/ Taille/ Taillenwijdte	64	67	71	75	79	83	87	93
Hüftweite/ Hip/ Hanche/ Heupwijdte	90	93	96	99	102	105	108	114
Vord. Tailleng./ Front waist length/ Longueur taille devant/ Taillelengte voor	42	43	44	45	46	47	48	49
Rückw. Tailleng./ Back waist length/ Longueur taille dos/ Ruglengte tot taille	41	41	41	42	42	42	42	43

Legende/ Legend/ Légend

Größe/	----	34
Size/	----	36
Taille/	----	38
Maat	----	40
	—○—○—○	42
	—*—*—*	44
	46
	————	48

For height 66 Inch:

Taille	34	36	38	40	42	44	46	48
Bust	31,5	33,0	34,6	36,2	37,8	39,4	40,9	43,3
Waist	25,2	26,4	28,0	29,5	31,1	32,7	34,3	37,0
Hip	35,4	36,6	37,8	39,0	40,2	41,3	42,5	44,9
Front waist length	16,5	17,0	17,3	17,7	18,0	18,5	18,9	19,2
Back waist length/	16,0	16,0	16,0	16,5	16,5	16,5	16,5	16,9

3C

3D

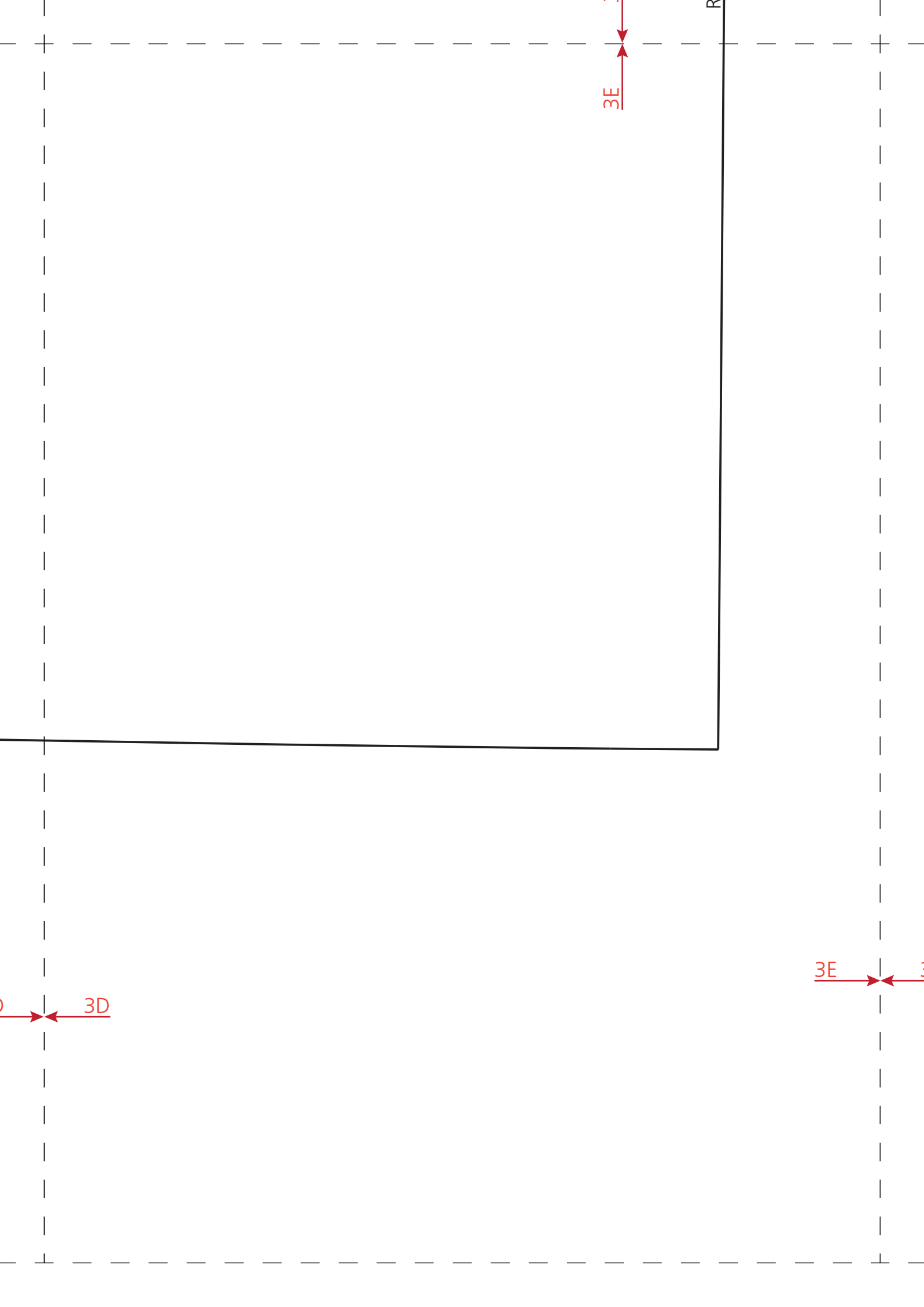

Keine Inspiration mehr versäumen – mit einem Abo! No more missing inspiration – with a subscription!



Ja, ich möchte die Inspiration ab der nächsten Ausgabe für 1 Jahr abonnieren (3 Hefte pro Jahr).

Yes, I would like to subscribe to Inspiration from the next issue for 1 year (3 issues per year).

Jeweils im Januar erscheint das Frühjahresheft, im Mai das Sommerheft und im September die Herbst/Winterausgabe. In allen Ausgaben sind Schnittmuster enthalten.

The spring issue is published in January, the summer issue in May and the autumn/winter issue in September. All issues contain pattern plans.

Land/ Country

- Schweiz/ Switzerland CHF 24
 Europa/ Europe EUR 21
 Übersee/ Overseas USD 38/AUD 54

alle Preise inkl. MwSt. und Porto/ All prices inclusive of VAT and postage

Sprache/ Language

- Deutsch/ German
 Englisch/ English
 Französisch/ French
 Niederländisch/ Dutch

Name

Geburtsjahr (optional)/ Year of birth (optional)

Strasse, Nr./ Street, no.

PLZ, Ort/ Postal code, town

Telefon - E-Mail/ Telephone no. - Mail

Mein Abonnement beginnt mit der jeweils nächsten Ausgabe. Es läuft nach Erhalt von 3 Heften automatisch weiter, sofern ich nicht rechtzeitig vor Ablauf kündige.

Subscriptions normally begin with the next issue. Subscriptions are automatically renewed after 3 issues if not cancelled in time before their expiry.

- Ich bin damit einverstanden, dass BERNINA meine Daten zur Weiterverarbeitung an Dritte (insb. die medienwerkstatt ag, Schweiz) übermittelt, sofern dies erforderlich ist, um die vertragliche Leistung in Anspruch nehmen zu können.
 I agree that BERNINA may transfer my data to third parties (esp. the media workshop AG, Switzerland and Datatrans AG, Switzerland), if this is required in order to make use of the contractual service.
- Ich bin damit einverstanden, dass meine Daten für Zwecke der Direktwerbung von BERNINA verarbeitet und mit anderen Informationen, die von BERNINA für denselben Zweck erhoben wurden, verknüpft werden. Weitere Informationen kann ich in der Datenschutzerklärung (bernina.com) einsehen. Diese Einwilligung kann ich jederzeit kostenfrei widerrufen.
 I agree that my data will be processed for direct marketing purposes by BERNINA and will be linked with other information which have been collected by BERNINA for the same purpose. I can find further information in the privacy policy (bernina.com). I can revoke this consent free of charge at any time.

**BERNINA International AG, Redaktion Inspiration, CH-8266 Steckborn, www.bernina.com
 E-Mail: redaktion@bernina.com / EN inspirtion@bernina.com**